

The "market wallet"

Presented by: Jeneur le Geline, jennifer_blaikie@hotmail.com

English "Market Wallet", "Martebo sack", "double carry sack", Swedish – "Fässing"

Further information

<http://www.larsdatter.com/wallets.htm>

<http://teffania.blogspot.com.au/2016/04/wallets.html>



British Library, Oscott Psalter, c 1265-1270

MS 5000 f.13r

http://www.bl.uk/manuscripts/Viewer.aspx?ref=add_ms_50000_f013r



British Library, The Luttrell Psalter, 1325 - 1335

MS 42130 f.88v

http://www.bl.uk/manuscripts/Viewer.aspx?ref=add_ms_42130_f088v



Martebo church, island of Gotland in Sweden, 14th Century

http://albrechts.se/wp-content/uploads/2012/08/martebo_01.jpg



Pierpont Morgan Library, Hours of Charlotte of Savoy,

MS M.1004, fol. 39r (Hybrid man (margin)), C. 1415-1430

http://utu.morganlibrary.org/medren/single_image2.cfm?imagename=m1004.039ra.jpg&page=ICA000131912



Pierpont Morgan Library, Hours of Charlotte of Savoy, MS M.1004, fol.003v, C. 1415-1430
<http://corsair.morganlibrary.org/icaimages/1/m1004.003va.jpg>



Martin Schongauer, The Nativity, C1480
<http://www.artbible.info/art/large/525.html>



MS. Douce 195, fol. 086v, roll 175A, frame 64, France end of 15th Century(Bodlian Library)
<http://bodley30.bodley.ox.ac.uk:8180/luna/servlet/view/all/what/MS.%20Douce%20195?os=50&sort=Shelfmark%2CDate>



MS. Douce 195, fol. 087r, France end of 15th Century(Bodlian Library)
<http://romandelarose.org/help/images/glossary/Cowl-Douce195folio%2087r-ann.jpg>



Pierpont Morgan Library, Book of Hours, PML M.116, fol. 68vr (Flight into Egypt), C. 1490-1500
<http://corsair.morganlibrary.org/icaimages/1/m116.068va.jpg>



Fortune and Poverty in De casibus (BNF Fr. 132, fol. 42v), c. 1470-1480
<http://visualiseur.bnf.fr/ConsulterElementNum?O=IFN-08101008&E=JPEG&Deb=4&Fin=4&Param=C>



A "Västgöta-knalle" in the 19th century.
A "knalle" was, in the old days in Sweden, a "travelling salesman". The drawing is from the book "Gamla Stockholm" by August Strindberg, 1912
<http://commons.wikimedia.org/wiki/File:V%C3%A4stg%C3%B6taknalle.tiff>



Pieter Breugel The Elder
The Fight Between Carnival and Lent c. 1559
https://commons.wikimedia.org/wiki/File:Pieter_Breugel_d._%C3%84._066.jpg

Construction methods

- 1) method http://home.swipnet.se/cybtex/sy/sew5_02.html,
dimensions <https://www.etsy.com/listing/163455581/the-fassing-bag-shoulder-bag>

a) Cut (60 to 80cm by 100 to 140cm)

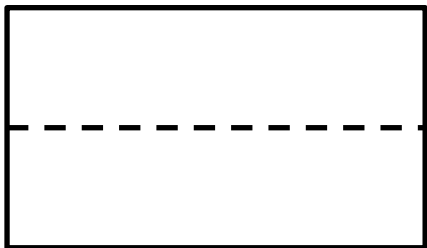

b) Fold in half (inside out)



c) Sew then turn right way

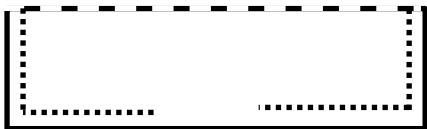

d) Load, twist and wear



- 2) <http://albrechts.se/tag/crafting/>

A) Cut (60 to 80cm by 100 to 140cm)

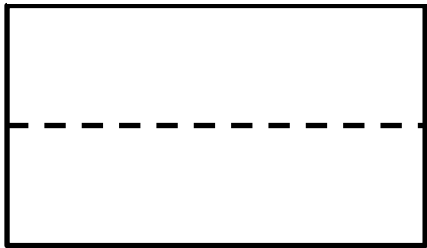

b) Fold in half (inside out)



c) Sew then turn right way



d) Cut slit and edge

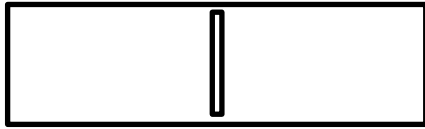

- 1) <http://albrechts.se/tag/crafting/>

a) Cut (30 to 40cm by 200 to 240cm) and finish short edges



b) Fold ends to the middle

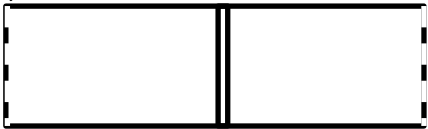

c) Sew then turn right way

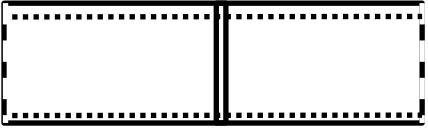

2) <http://www.outwatersmilitia.com/images/2011/Newsletter12/News12.html>

a) Cut (60 to 80cm by 100 to 140cm) and finish long edges

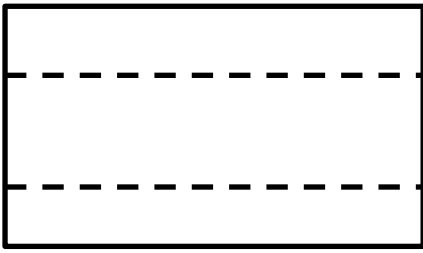

b) Fold sides to the middle

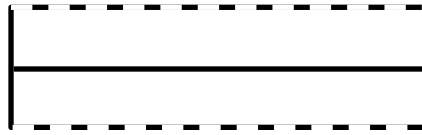

c) Sew then turn right way

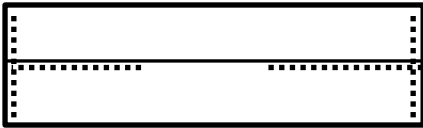

Dimensions for an 18th C original

<http://www.18cnewenglandlife.org/18cnel/wallets.htm#Market%20Wallet>

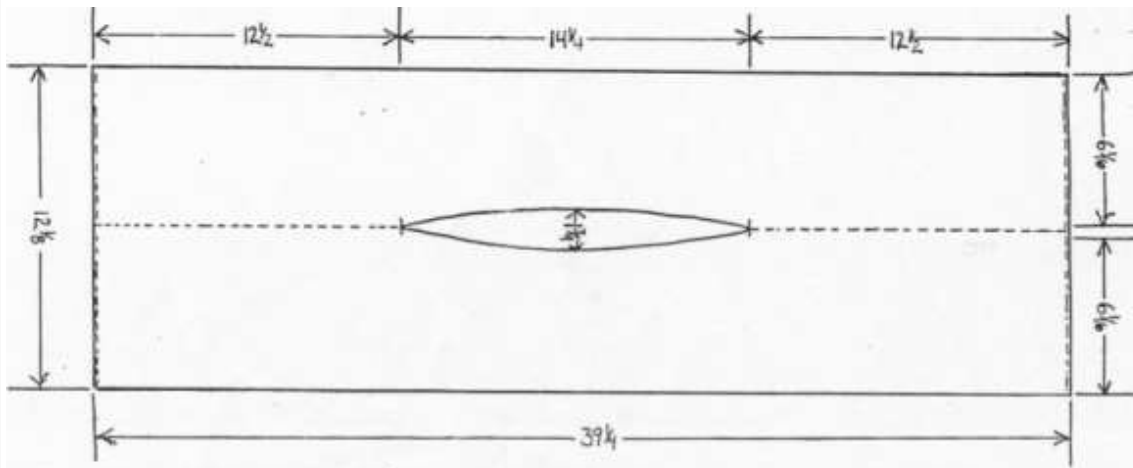

3) <http://uploads.ifokus.se/uploads/7ff/7ff6e392d2b41834d444db23fce6d7a3/002.jpg>

